



WHITESIDE MACHINE COMPANY

Instructions for

# Miniature Train Tracks



4506 Shook Road - Claremont, NC 28610  
800.225.3982



## BEFORE YOU BEGIN

Whiteside's carbide tipped Train Track bits cut the male and female connections for a child's wooden train track. The bits are designed for use only in a router table – do not attempt to use them in a freehand application. A thorough knowledge of router table use is necessary to use these bits. These instructions have been written to provide you with a better understanding of setup and cutting procedures. If it is your intent to duplicate existing track that you might already have, we recommend that you ignore the measurements given in these instructions and take new measurements directly from your track. Please thoroughly read these instructions before starting any cutting operations.

Remember that the joints you cut are for a child's toy and not a piece of furniture. Joints should be cleanly cut but the fit is not critical. In fact, the connection between the male and female cuts should be fairly loose so that the child does not have difficulty assembling and disassembling the track.

Please adhere to all safety procedures while using these and any other router bits. Read all tool manuals before any cutting operations are attempted. Always wear proper safety equipment including safety glasses.

Router Bits Needed for this project:	Whiteside Part # 3900	Ball Cutter (Female Connector)
	Whiteside Part # 3902	Half Round (Male Connector)
	Whiteside Part # 3910	Single Groove Bit
	Whiteside Part # 3915 (Optional)*	Double Groove Bit

\*See "Train Track Grooves" paragraph on Page 3)

## RIGHT ANGLE FIXTURE

A right angle jig or fixture, in conjunction with the router table fence, is required to machine the track. There are several commercial jigs and fixtures on the market that you can use. We made ours from scrap plywood. Whether store bought or shop built, the fixture should be able to hold a piece securely in a vertical position. Photo 1.

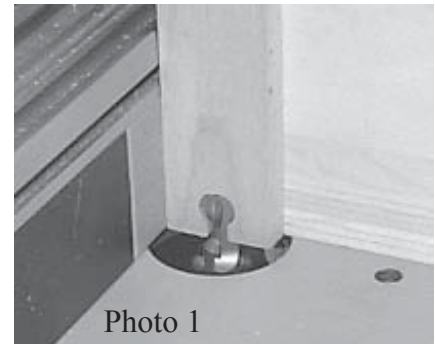

Photo 1

## MAKING STRAIGHT TRACK

### Straight Track

Straight track is not limited to any one length, although you should keep the length within a reasonable dimension so machining the part is not difficult. Common lengths for store bought track (excluding the male connector) are 4-1/4", 5-3/4" and 8-1/2".

Determine the length of your track while keeping in mind that the overall length of the piece with the male connection is longer than the dimension of the track. An 8-1/2" piece of track is actually 9-3/16" OAL when you add the 11/16" length of the male connector.

Because it is difficult to repeat exact router table setups time after time, we suggest that you machine several pieces at a time to take advantage of each setup.

### Straight Track Blank Dimensions

The Blank for a straight piece of track should be 7/16", 1-9/16" wide and the length of your choice. Drawing 1.

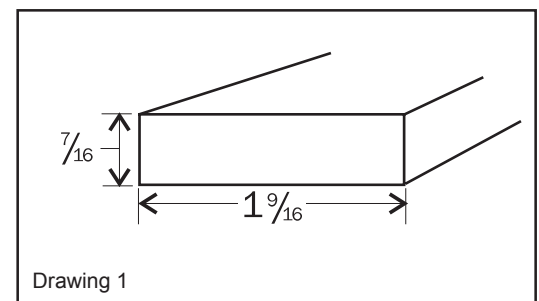



## Routing Female Connectors

**Note:** We highly recommend pre-cutting most of the material around the joints so that your router bits can work more effectively. Drawing 2, Photo 2.

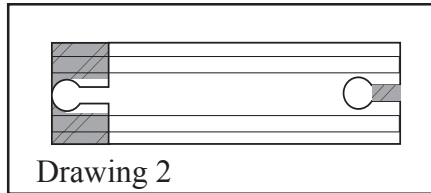

Drawing 2

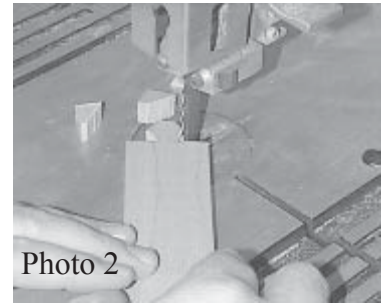
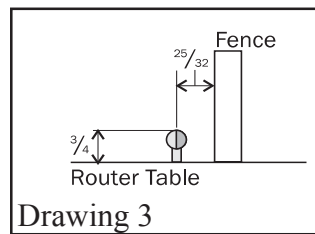

Photo 2

Place the Ball End Bit (**Whiteside Part # 3900**) into the router in your router table and set the height of the bit at  $\frac{3}{4}$ ". The distance from the fence to the center of the bit should be  $\frac{25}{32}$ ". Drawing 3. This puts you in the center of  $1\text{-}9/16$ " stock. Remember to pre-cut a small opening at one end of the blank to take some pressure off of the bit and ensure a cleaner cut. Drawing 2. With the right angle jig against the fence, position the blank  $90^\circ$  to the table, flush to the fence and right angle fixture and secure with a clamp. With the right angle fixture firmly up against the fence, move the jig through the router bit at a steady pace and make the cut. Make one pass and do not bring the blank back over the cutter. This will result in a double cut and possibly a kickback situation. Machine all straight blanks with this setup. This cut will be used as a reference for the male cut. Photo 3.



Drawing 3

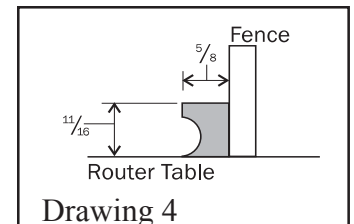

Photo 3

**Note:** If chip out occurs on the back side of the track blank, place a piece of stock behind the blank. This backer board will support the stock and the chip out will occur on it and not on the track blank.

## Routing Male Connectors

Pre-cut the opposite end of the track blanks. Drawing 2. Place the Male Connector Bit (**Whiteside Part #3902**) into the router in your router table and set the height of the bit at approximately  $\frac{11}{16}$ ". The distance from the fence to the upper outside edge of the bit should be approximately  $\frac{5}{8}$ ". Drawing 4. With the right angle jig against the fence, position the end of the blank  $90^\circ$  to the table, flush to the fence and the right angle fixture and secure with a clamp. Move the jig through the router bit at a steady pace and make the cut. Flip the stock and repeat the cutting process (this will ensure that the cut is exactly centered on the blank). Fine adjustment can be made to this cut by moving the fence in or out from the bit. Check the fit of the male/female connections at this time. Remember that the fit should be loose enough that a child has no difficulty putting together or taking apart the wooden pieces. Make any adjustments needed for a better fit and then machine all straight blanks with this setup.



Drawing 4

## Train Track Grooves

The train track grooves are approximately  $\frac{1}{4}$ " wide,  $\frac{1}{8}$ " deep and 1" on center. This cut is made with the Single Groove Bit (**Whiteside Part # 3910**). Bit height is  $\frac{1}{8}$ " and the distance from the center of the bit to the fence is  $\frac{5}{16}$ ". Drawing 5. Using a push block hold the track blank firmly to the table and up against the fence. Photo 5. Move the blank over the bit with a steady pace. Flip the stock and repeat the process along the other edge. (**NOTE: Whiteside Part #3915** may be used as an alternative to cut both track grooves at the same time. The board must be set on its edge to use this bit. **Part #3910** is required for curved track.)

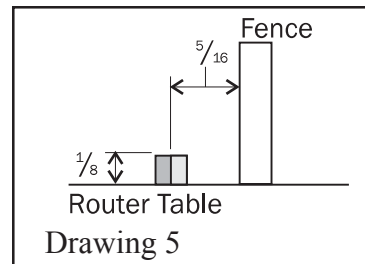

Drawing 5

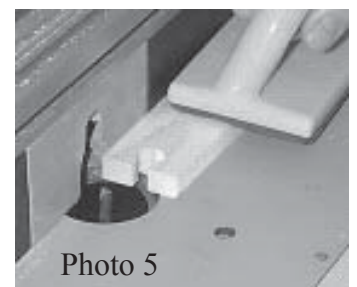
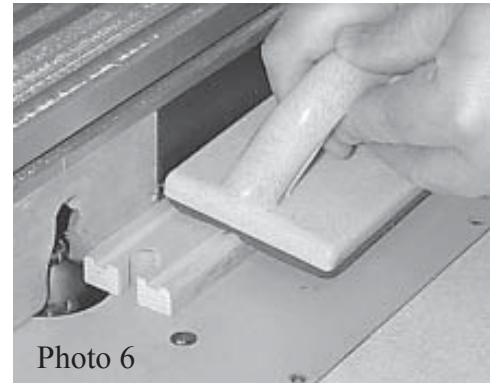
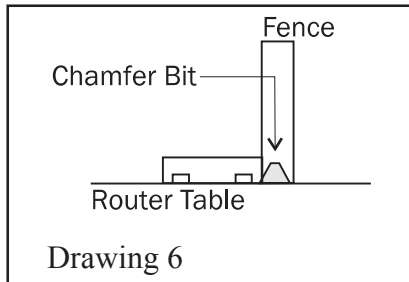

Photo 5



Outside edges of the train track can be eased with sandpaper or by using a chamfering bit. The chamfer should be very slight, only 1/16", just enough to soften the edge. Drawing 6. Photo 6. Completed track can be left natural or finished with a child safe, nontoxic finish.



## MAKING CURVED TRACK

Making the curved track requires a circle cutting jig that will hold a precut blank of wood and a right angle jig to hold a curved piece of wood rather than a straight one. The completed curved track is 1/8<sup>th</sup> of a circle with track grooves on both sides. Making curved track requires cutting track grooves that are partial arcs of two concentric circles. To make these cuts you will use two different centers on your router table.

Make a circle template from a piece of scrap plywood about 11" x 13". Draw a center line lengthwise along the jig. Drill a 3/16" pivot hole, on the center line, about 2" from one edge. Mark a 90° guide line on the template 6-11/16" from the center of the pivot hole. This will mark the position of the wood blank on the template. Drawing 7. Cut several track blanks 7/16" thick, 3" wide and 8" in length. Place a blank on the jig at the 90° guide line and glue support blocks around its perimeter. Glue a support block that is the same thickness as the track blank near the pivot hole, this will support the jig so that it will stay level with the table. Drill holes for the "centers" of the arcs into your router table. The center of the first hole should be 8-1/4" from the center of the bit. The center of the second hole should be 1" farther from the bit than the center of the first hole. If you can't drill directly into your table, clamp a false table top of 3/4" plywood over your table. Drill a clearance hole for the router bit, then drill your center holes into the false table. The position of these centers needs to be as accurate as possible.

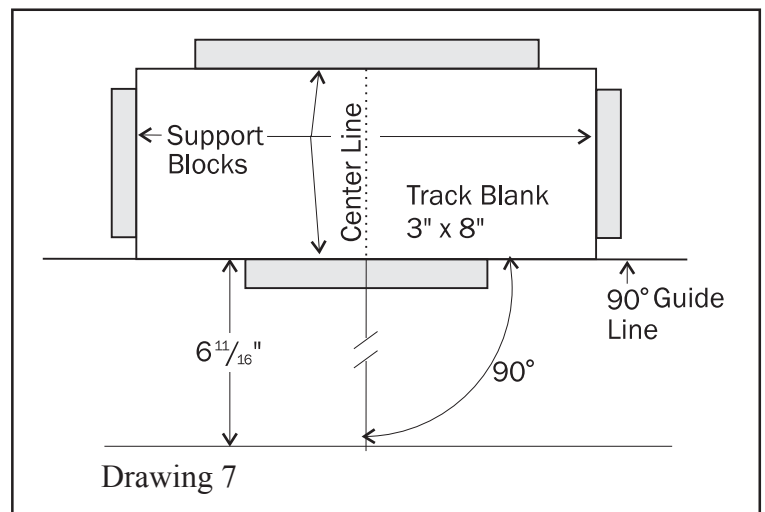

**Tip: We used a 3/16" bit to drill our center holes and then used that same drill bit as the pivot point for our jig.**





Place the Single Groove router bit (**WhitesidePart #3910**) into the router at a height of 1/8" above the table. (**NOTE:** The optional Part # 3915 can not be used on curved sections of track). Place a pre-cut blank into the jig. Place the jig on the table and put the pivot point through the jig and then into the first center hole. Turn the router on and slowly swing the jig through the bit in a counter clockwise direction. **WARNING: Do not bring the jig back through the bit. This will result in a double cut and possibly cause a kickback situation.** Move the pivot point into the second center hole, turn on the router and slowly swing the jig through the bit again in a counter clockwise rotation. Flip the track blank over and repeat the process so that grooves are created on both sides of the blank for right or left turns! (Photo 9).

## Cutting The Angles On The Groove Track Blank

Use a table saw, miter guide and the dimensions in Drawing 8 to make the angled cuts on the grooved blanks. **IMPORTANT: You will machine the male cut on the right side of the track (as shown in the drawing) and the female cut will be made on the left side. Mark this information on the track blank.**

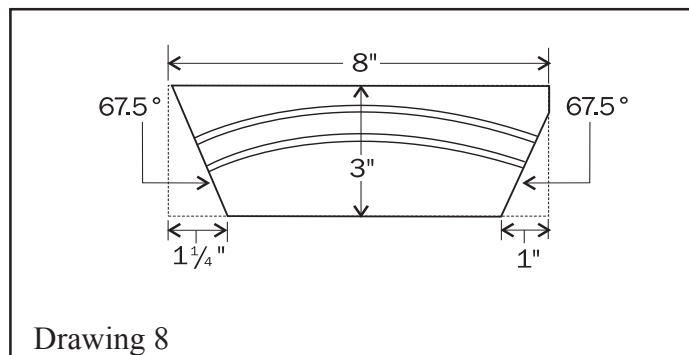

Drawing 8

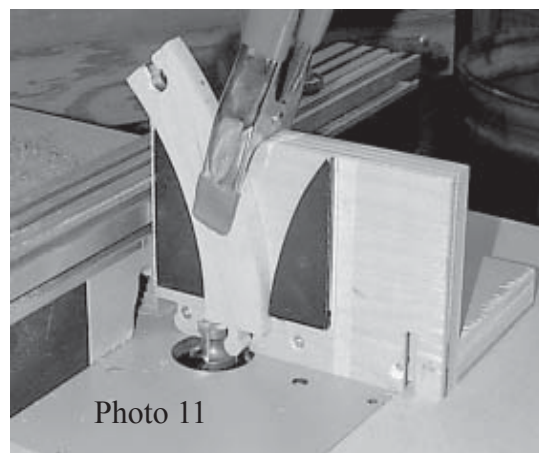

Photo 11

## Cutting Inside And Outside Edges

Draw a guide line to mark the inside and outside edges of the track 3/16" away from the track grooves. These edges of the track should be cut on a band saw and then sanded. Photo 12, Photo 13. The width of the curved track is only critical at the ends where they should be 1-9/16" wide, identical to the straight track. This is an important dimension because you'll be using the same technique to cut the connectors as you did with the straight track and you'll want a smooth fit when the track is assembled.

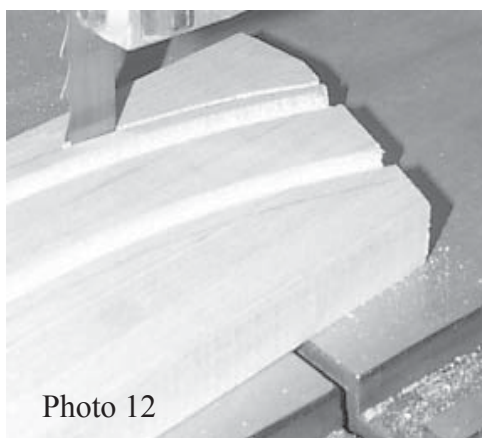

Photo 12

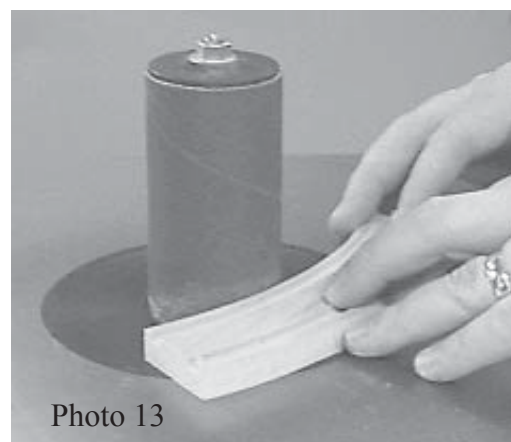

Photo 13



### Right Angle Fixture For Curved Track

The next step involves modifying the right angle jig to accept and support the curved pieces of track so that the male and female ends can be machined. Transfer the inside radius of your curved track onto two pieces of scrap plywood. Cut this plywood along the inside radius lines and attach them to the face of your right angle jig 1-9/16" apart from each other. Drawing 9. You can use a piece of track to help position the plywood support blocks on the right angle jig. The location on the face of the jig is not critical. You will set the female cutter bit in the center of the opening between the plywood supports.

The procedure for cutting the connectors on the curved track is similar to that of cutting the straight track. Bit heights remain the same, but the distance from the fence to the bit depends on where you located the curved supports on the face of your right angle fixture. Remember that the ball end cutter

(Whiteside Part # 3900) is centered on the track. Drawing 9, Photo 14. The male cutter (Whiteside Part #3902) is offset toward the fence side and the cut is made in two passes, by flipping the stock. This is a trial and error process. You have the ability to make adjustments to the male connector by moving the fence in or out until the resulting cut fits into the mating track. Drawing 10, Photo 15. (Curved supports are painted for visual clarity). Once again we recommend that you pre-cut all the ends to be routed. See Drawing 2.

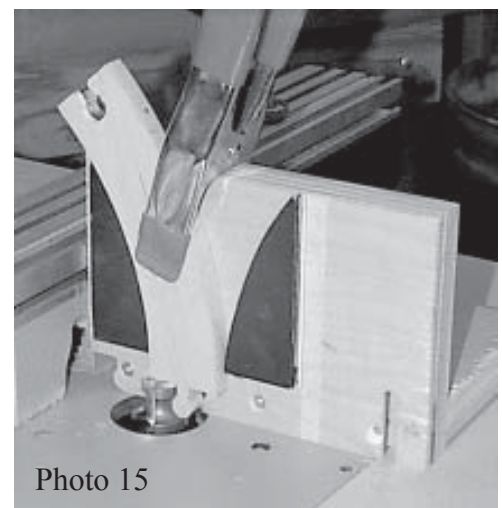
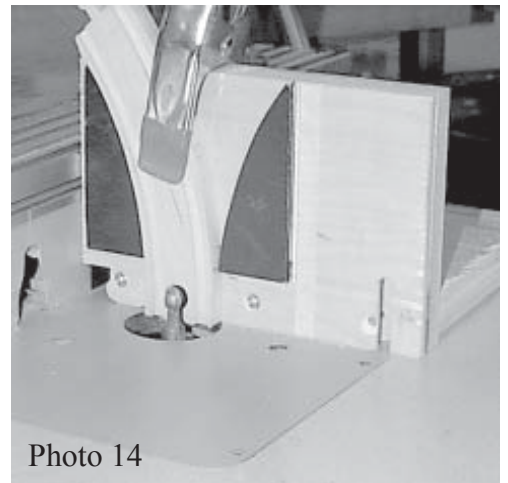
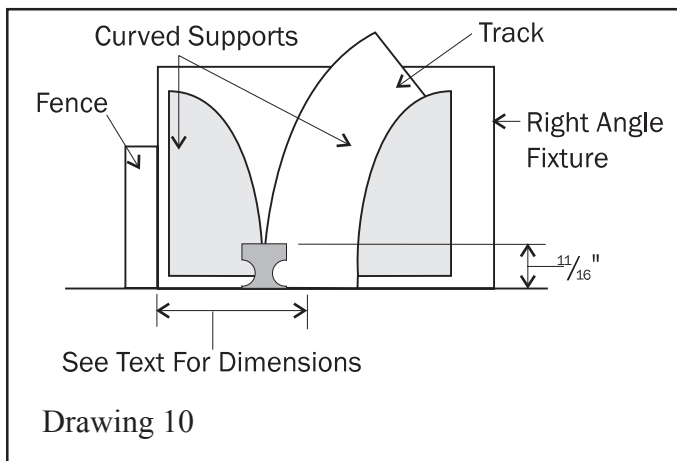
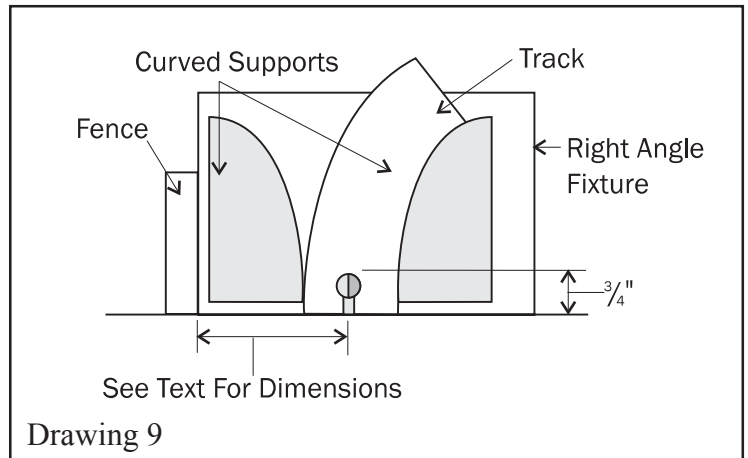

We hope you enjoy discovering other uses with these bits.

We wish to thank Woodcraft® Supply Corporation for sharing their drawings, photographs and instructions on making the Train Tracks.